



IsatDock2 Lite (ISD2 LITE) FAQ

Powering Up/Restarting

My unit powers off once the ignition is switched off or the key is removed after 20 minutes.

This is normal operation; however, connecting the ACC cable to a constant power source on the vehicle/vessel will rectify this, if such an operation scenario is required.

No Power on IsatDOCK

Check power is connected to the interface unit.

If applicable, check the vehicle ignition is in ACC or IGN or ON position.

Ensure the Connector cable to the IsatDOCK is firmly fitted.

Check all the connection cables to and from the IsatDOCK.

IsatPhone Pro does not stay powered on

Remove the IsatPhone Pro, remove the battery and reinsert again into the docking station ensuring the connection is firm and clicks into place.

The IsatPhone Pro prompts me "Enable charging? Y/N"

If the IsatPhone has firmware version 4.0.0 loaded, this message will appear when the phone is powered on for the first time. Please select Y (Yes) to enable charging.

This message will not appear again, unless the phone is reset to factory defaults via the menu.

If you do accidentally select N, you will need to re-upgrade the firmware on the IsatPhone Pro and select reset to factory defaults.

My battery has stopped charging?

After the IsatPhone handset in the IsatDOCK becomes 100% fully charged, the battery will stop charging until the voltage drops below 4.1V. Then it will start charging again, provided the Internal Board Temperature of the IsatDOCK (taken from Falcon) is less than or equal to 38C. The IsatPhone Pro battery is a lithiumion cell which has a safety temperature range whilst charging of 0 to 45 degrees Celsius (32 to 113 degrees Fahrenheit). Due to the increased heating effects on the IsatPhone Pro handset whilst it is docked and being charged, it is ideal for the ambient temperature to be at least 18 degrees below the 45oC upper limit for the handset to charge the battery whilst docked. If the battery temperature exceeds this limit, then the IsatPhone Pro may cease charging until the temperature is reduced. The battery itself will not charge until the core temperature drops below the 45C point.

We are planning to install the DC connector directly to the car wiring, what is the PIN out of the connector for the Docking Station.

The pinout looking into the 4-way connector of the Docking Station (attached) is:

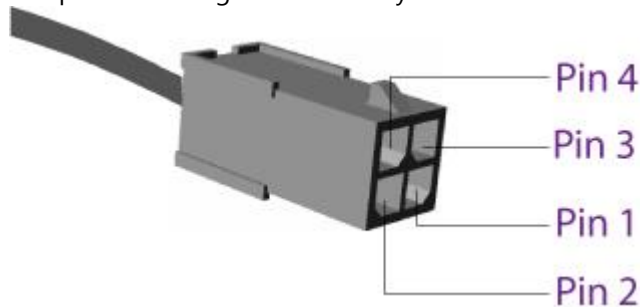

Pins 1, 2 and 4 are used:

Pin 1 = Acc

Pin 2 = GND (0V)

Pin 4 = Constant Vin (+ve)

The docking station appears to be turning ON/OFF and the handset is not registering.

Ensure the power supply can provide at least 3.5A at 12 volts.

If power is being supplied from a battery, ensure the connections are right and the contacts are clean.

Ensure that the docking station has the latest firmware installed.

Battery is not charging in the cradle.

Ensure the ambient temperature is within the specifications for charging the battery.

See "Charging the IsatPhone Pro handset whilst in the DOCK" in the User Manual.

See "Charging the Iridium handset whilst in the DOCK" in the User Manual.

Allow up to 100 seconds before charging begins

Check to make sure that the connector cable is connecting properly

Ensure the 12V DC cable has not become loose or disconnected

Ensure the 12V DC cable was installed correctly

Ensure the USB symbol appears on the IsatPhone Pro when inserted into the DOCK – to ensure connection.

Cycle power to cradle and phone and try again?

The phone will not operate in handheld or in vehicle mode.

Check your SIM is inserted correctly in the handset.

Check your battery is charged.

Refer to your service provider.



IsatPhone Pro displays "Registering"

Ensure your phone's antenna is fully extended.

Ensure your phone's antenna is pointed towards the satellite. Press Help for onscreen guidance.

Consult the Coverage map on page 8 of your IsatPhone Pro Manual to ensure you are within coverage.

Ensure there is a clear line of sight to the satellite with no obstacles which could block the signal.

USB communication failure between the Docking Station and the IsatPhone Pro.

Remove the battery from the IsatPhone Pro and re-power the Docking Station before re-inserting the IsatPhone Pro

Check the firmware of the Docking Station ensuring you have the latest.

My Terminal/Docking Station continues to display "Searching Satellite/Network."

Ensure your terminal's antenna is installed where there are no obstructions and has a clear line of sight to the satellite with no obstacles which could block the signal.

Check the antenna cable and all connections are secure and no bends or breaks/cuts in the cable.

Check for any RF interference near the antenna that may be causing problems. If there are any, shut them down and re-test, if your set-up works okay now, then you will have to relocate the antenna elsewhere.

Check with your service provider that the service has been activated and that you have received the correct SIM card (in case of Inmarsat services)

Check your coverage map to ensure service is available at your location.

If problem persists, contact your service provider.

Can I use a Fleet Sim Card in my Terra terminal or IsatDOCK?

No, you cannot. A Fleet Sim Card is designed for the Inmarsat Fleet maritime satellite phone service. As such a Fleet Sim Card will only work successfully in an Oceana Unit.



DATA

How do I use Data with my Inmarsat device?

To enable your Inmarsat device for the data service:

1. Connect the docking station to your PC using the USB cable.
2. Initially you will need to install a standard USB Modem Driver to work with the Docking station. To do this, on your PC go to Control Panel > Phone and Modem options and select the Modem Tab. Select Add > make sure you tick Don't detect modem I will select from list then NEXT >. Select the Standard Modem type and 2400bps Modem. Click on NEXT > It will prompt you know to select the Comport that it is attached to.
3. Highlight the modem driver you have just created and click on PROPERTIES > ADVANCED. In the Extra initialization command key in the following: &FE0&D2 OK>
4. Place your phone into the Docking Station ensuring it has signal when inserted and ready for service. (If Applicable)
5. Identify the modem COM port to which your device is connected for the data service. The COM port number will be needed when you are using your data application. To do this, on your PC go to Control Panel > Phone and Modem options and select the Modem tab. You will see Standard 2400bps Modem and the COM port eg. COM6. Or, go to Control Panel > System and select the Hardware Tab. Click on Device Manager and scroll down to Modems. If your USB drivers are installed, you will see Standard 2400 bps Modem. Right click on Standard 2400 bps Modem and select Properties. You will see the Com port eg. COM6.
6. If you have not already done so, install your chosen data application and follow the on screen instructions.

Unable to make a data call or get 'No Carrier' when using SkyFile Mail

Ensure the SIM is correctly provisioned to make mobile originated data calls. Signal strength must be adequate, and the registration obtained with the Provider's network. On initial power up, registration normally takes about 20 to 40sec, and may vary. Please ensure that SIM PINs are correctly entered, and prompting is disabled if not required

Why does my Internet connection keep dropping while I am using the Internet?

This problem occurs when signal quality is an issue. Users who are attempting data calls from inside of a building also tend to have this difficulty. When your call drops, look at the signal strength indicator in the corner of the LCD on the phone or your PC and verify that your signal is in the range of 4 to 5 bars. If you are not getting 4 to 5 bars of signal, you may want to adjust your antenna to get a better view of the sky. If the problem persists, please contact the dealer through whom you purchase service.



What are the Supervisor PIN, and the Security Code numbers?

The supervisor PIN for ALL Beam products is set to the default '3170'. The PIN can be changed on the 'Programming - Security' tab in the relevant Management System software. Take care in changing this code, and be sure to remember the new code.



FIRMWARE / SOFTWARE/ CONFIGURATION

Why am I having trouble upgrading firmware?

Please ensure you have downloaded the latest version of the Beam Management System software from our support website for your specific product.

Extreme DOCK = Eagle

PotsDOCK / IntelliDOCK= PDMS

SatDOCKG = SDMS

IsatDOCK / Oceana & Terra = Falcon

RST100 = BMS

IridiTRAK - IMS

In addition please try the following process:

- Restart the PC
- Removing the USB cable from the device to the PC
- Power cycle the device
- Reconnect the USB cable from the device to the PC
- Retry upgrading firmware

How do I upgrade the firmware on my Beam satellite device?

To upgrade the Firmware on all of our products you must first download the Management System designed for your specific device

Extreme DOCK = Eagle

PotsDOCK / IntelliDOCK= PDMS

SatDOCKG = SDMS

IsatDOCK / Oceana & Terra = Falcon

RST100 = BMS

IridiTRAK - IMS

These can all be found under the Support Section of each product and then Resources.

In addition, please try the following process:

- * Restart the PC
- * Removing the USB cable from the DOCK to the PC
- * Power cycle the DOCK
- * Reconnect the USB cable from the DOCK to the PC
- * Retry upgrading firmware

What are the err (error) codes in the Log?

Refer to the Beam Management System Software Help tool. Click on "Help?" then 'Status'.

How do I know what firmware is running on my terminal or docking unit?

Use the relevant Beam Management system available from the support page under "Resources" on the support page via the Log / Data USB Port. The Status tab will display firmware versions.



SIGNAL / ANTENNA

Can I use any kind of cable in combination with my Inmarsat Active/Passive Antenna?

Only cable kits supplied by Beam will operate correctly with the Inmarsat antennas. Each cable kit has been made to meet the specific specifications of the antenna and Inmarsat network. The cable kit not only provides Satellite connectivity but also GPS which is required for the Inmarsat service to function correctly. In the case of Active Antennas, then the cable kit also provides power to the antenna as well. You must use Passive cable kits with the ISD700 and Active cable kits with the ISD710/715 and 720. Failure to use the correct Beam cables can damage the antenna, stop the service from performing properly and void your warranties.

What is the maximum length of antenna cable I can use with my Active Inmarsat Antenna?

Antenna cables for the Active Inmarsat Antenna start at a length of 6 meters and go up to 100 meters. Custom cables can be made longer if required. Please see your Beam Authorized Reseller.

What is the maximum length of antenna cable I can use with my Passive Inmarsat Antenna?

Antenna cables for the Passive Inmarsat Antenna start at a length of 10 meters and go up to 50 meters. If you need to go longer, you may be better off looking at using an Active antenna to get access to the longer cable kits.

I am using the Beam recommended antenna cable with an Active antenna, yet I don't get a proper connection, what can I do?

Make sure that the cable is correctly connected to both the antenna and the unit. Also, please check whether there are no kinks in the cable. See the cable kit specifications to ensure the maximum bend radius has not been exceeded anywhere. Also check the cable kit has not been altered in anyway, the cable kits CANNOT be shortened.

Check that the antenna is positioned properly, has a clear view of the horizon and there are no other obstacles or RF interference. Also check the Inmarsat coverage map to ensure coverage is available at your location.

Beeping sound coming from Docking Station

The beeping noise usually indicates a short on the antenna cables which can be caused by a cut or break in the antenna cable or caused by metal debris inside a connector. Please disconnect the antenna cables from point where they (gps and Inmarsat) connect to the docking station. When completed, please power cycle the unit and see if the noise continues.

If it stops, please inspect the antenna connectors and ensure they are clear and that there are no cuts or sharp bends on the cables. Also check the connectors as they screw into the antenna and ensure both connector ends are clear and free of anything that may cause a short from the central pin to the connectors metal casing.



Does RF Interference affect the satellite signal?

All wireless devices, including satellite telephones, are susceptible to RF (Radio Frequency) interference from other electronic devices. This problem is especially evident when numerous antennas and broadcasting devices are located within close proximity to each other.

A good example would be onboard a ship. It is important that certain considerations be taken into account for best performance when an Iridium system is installed.

Causes of RF Interference:

Some subscribers have contacted Iridium regarding the loss of signal quality when they operate their equipment near active INMARSAT terminals. The power with which INMARSAT units transmit can overpower the Iridium unit's ability to properly maintain a quality connection with the Iridium satellite constellation. INMARSAT terminals are often found in the same locations as Iridium subscribers, such as harbors, airports and especially onboard ships.

The location of the INMARSAT unit's antenna in relation to the Iridium unit's antenna plays a significant role in determining the degree of signal degradation that an Iridium subscriber can expect to experience. All Iridium units are susceptible to this interference, regardless of the type of antenna being used.

Generally speaking, an Iridium unit, be it a handset using its integral antenna or a fixed terminal when attached to an externally mounted antenna and located within 15 and 45 meters (50 to 150 feet, respectively) of an operating INMARSAT Mini-M / GPS / Fleet phone / IsatPhone link or Standard-C terminal, will likely experience degraded performance.

Inmarsat antennas can experience interference from other Inmarsat devices as well as radar or broadcast services and other RF transmitting devices.

Other sources of RF interference such as Globalstar units, radar devices and broadcast stations can provide interference for Iridium units, but usually are not encountered as frequently as INMARSAT terminals.

Refer also to Inmarsat/Iridium Antenna User Guide.

How do I know if my IsatPhone Pro is registered on the Inmarsat network?

The IsatPhone will indicate "Inmarsat" in the top left corner of the screen display and when the handset is registered and able to make calls on the network.

What is the difference between a Passive and Active Antenna?

The exact difference is the Passive antenna is a non-powered Directional antenna that can ONLY be used in fixed applications where the antenna will never move. This antenna does require to be manually pointed at the Inmarsat satellite when initially installed.

What is the difference between a Passive and Active Antenna?

The Active antenna is a Powered omni directional antenna that can be used for mobile applications where the antenna will move like on a ship or vehicle. The antenna doesn't require manual pointing to the satellite. The power to the antenna is provided by the docking unit and does not require an additional power source.

Any Beam Inmarsat Dock or Terminal can support any Active or Passive Inmarsat antenna.



My Terminal/Docking Station continues to display "Searching Satellite/Network."

Ensure your terminal's antenna is installed where there are no obstructions and has a clear line of sight to the satellite with no obstacles which could block the signal.

Check the antenna cable and all connections are secure and no bends or breaks/cuts in the cable.

Check for any RF interference near the antenna that maybe causing problems. If there is, shut them down and re test, if works ok, then you will have to relocate the antenna elsewhere.

Check with your service provider that the service has been activated.

Check your coverage map to ensure service is available at your location.

If problem persists, contact your service provider.

My phone does not display a GPS position.

Some national policies do not allow users to access their GPS information in particular locations.

Your terminal continues to access the GPS satellites as usual, but your terminal will not display its GPS location.

How do I know if my Oceana800/Terra800 or IsatDOCK is registered on the Inmarsat network?

The STATUS LED will change to GREEN when the terminal is registered and able to make calls on the network.

The signal bars are low or fluctuating and call quality is poor on my Inmarsat Service.

Ensure all antenna connectors are tight.

Make sure the antenna is operating in a location where it can see the satellite and there are no obstructions.

Ensure that BEAM certified antenna cabling is being used and that there are no sharp bends or cuts in the cable, and the cable has not been modified in anyway.

If using a fixed passive antenna, ensure it is orientated correctly and pointing at the satellite.

Can I install Surge Arrestors with my Inmarsat products?

There is a possibility to use a Surge Arrestor with the Inmarsat Docking Stations. Please contact your Beam Reseller for pricing. The lead time for these cables will be approx 3-6 weeks after placing the order.

The Satellite device fails to register with the Satellite service after 60 seconds.

Check power connection

Check antenna connection and location

Check whether the antenna cable is connected properly

Check cable specs to ensure that your system is operating within the required network specifications

Ensure SIM is inserted and correctly provisioned

Check whether correct power supply is being used



SIMPIN / PUK / PHONE LOCKING

Why doesn't my SIM card work?

Is the card inserted the correct way?

Is the gold chip visibly damaged or scratched? If so, return the card to your service provider.

Check the SIM and phone contacts. If they are dirty, clean them with an antistatic cloth.

What is a SIM PIN?

The Subscriber Identity Module (SIM) often referred to as a simcard, typically is provisioned and issued by a Service Provider (SP) with an associated Personal Identification Number (PIN), sometimes referred to as PIN1. It is possible to request simcards without PINs. When the satellite device first powers on, if the unit is set to request that the user enters the PIN code then until this has been successfully completed, the unit will not register, place calls or receive calls.

My SIM PIN is blocked?

If you enter the PIN incorrectly 3 times, the SIM card locks, and you need to enter the PUK. You must use the PUK code supplied by your Service Provider to unlock the SIM. If you don't have a PUK code, please contact your Service Provider.

The Terminal / Phone or SIM has been lost or stolen.

Contact your service provider as soon as possible so your terminal / phone or SIM can be barred.

Your PIN2 is locked

Enter the PIN2 unblocking key (PUK2) or contact your service provider.



VOICE

How do I use Bluetooth with IsatDock's?

The Bluetooth functionality works from the IsatPHONE Pro to the Bluetooth once it is inserted into the Docking Station the Bluetooth will override the speaker. Once the BT headset is paired and connected, you will be able to hear the call progress tone in the dock's speaker or PHS (if it is uncapped). But as soon as the remote end starts ringing the audio gets connected to the BT headset. Similarly, while receiving a call, the ringer can be heard in speaker but once the call is answered the audio gets connected to the BT headset.

One point to be noted here is that after the BT is paired it still needs to be connected as well. If it is not connected, then it won't work!

To activate the Bluetooth:

To activate Bluetooth connectivity select Menu > Settings > Bluetooth.

Select Settings > Bluetooth and select On. The Bluetooth icon indicator appears in the status bar.

Connecting a new Bluetooth device

The first time you use a particular Bluetooth headset with your phone, you will need to pair the phone and the headset. Ensure the Bluetooth headset is switched on before you begin. Select Menu > Settings > Bluetooth > Paired devices. A list of Bluetooth devices in range of your phone will appear on the screen. If the device does not appear, select Options and select Search for devices from the new menu that appears. Searching... will be displayed at the top of the screen, followed by the names of all the devices in range. A blue tick will be displayed next to any devices already paired with your phone. Select the device you want to pair and enter its pass code. Bluetooth devices such as headsets generally have their pass code set in the factory and printed either on the device or its packaging. Some devices allow you to set the pass code yourself.

The device should now be listed in the Paired devices menu. Highlight it and press the left selection key, then select Connect from the menu. The device should now be listed on the Connected devices menu accessed from the Bluetooth menu. This icon indicates that your phone is connected with a Bluetooth headset. Whenever the device attempts to make a connection with your phone, you will be prompted whether you want to accept the connection. To automatically accept connection requests from a particular device, highlight it in the Paired devices menu, select Options and select Set as authorized. You should only authorize devices that belong to you, or that you trust. If you no longer want a device to be authorized, select Set as unauthorized.



Why is incoming call not ringing on Docking Station?

Check on the IsatPhone Pro that it has not been set to Silent or Vibrate.

Check the Firmware version of the Docking Station and upgrade if not the latest.

Why don't I get any audio to the satellite phone from uplink?

If unable to obtain uplink audio whilst using the satellite phone, this can be caused by a communication failure in the satellite phone.

Check the base of the phone connectors ensuring contacts are clean and that the connector pins in the docking station are straight and clean as well.

Remove the satellite phone from the cradle, remove the battery for 10 seconds, replace and redock into cradle.

Why is voice quality poor?

Ensure the signal strength is at 4-5 bars.

Check antenna and cable - ensure all connections are correct and intact.

Check your location and for interference.

Satellite networks have a slight delay in processing the call.

My Terminal/Docking unit does not seem to be receiving voicemails.

Ensure your service provider has enabled voicemail.

Check that you have set up the Voicemail correctly and that you have the appropriate diversions to Voicemail.

If you have not used your terminal, or connected to the network for some time, it may be that your voicemails have been automatically deleted from the network. Ensure that you connect to the network at regular intervals.

Party B cannot hear your voice

Privacy Handset must be docked in its cup when not in use (if applicable).

Check that MUTE is not ON (indicated by turning **RED**).

Check the signal strength on the handset.

Check external microphone connection (if applicable).

Ensure the Headset connector at the base of the Isatphone is not obstructed and there is no dust or foreign objects in the connector socket (if applicable).

Ensure you have the latest firmware version on the handheld device (if applicable).

Ensure you have the latest firmware version on the Beam terminal.

Dropped Calls

Due to how a satellite network is configured, if you are in motion, the satellite signal may become obstructed (such as buildings, bridges tunnels, larger vehicles, valleys, large trees)

Check the antenna connections.

Ensure the antenna cable has not been damaged.

Ensure that only approved antenna cable is being used.

Refer to Antenna Installation Guide on Beam website support.

If problem persists, contact your service provider



My terminal/IsatDOCK cannot make or receive calls.

Ensure the SIM card is inserted in the phone and is fully provisioned by your service provider.

For IsatDOCK units ensure the USB symbol can be seen on the IsatPhone display

Check whether you have a valid GPS fix.

If the phone has sufficient signal strength and cannot make or receive calls, check if Call barring, diverting calls or Fixed number dialing have been activated.

If you have a prepay subscription, check yours prepay balance to ensure you have sufficient credit to make a call.

Contact your service provider if you are unable to resolve the problem.

I am unable to make a call.

Check that the antenna is properly mounted.

Check the phone is registered onto the network.

Do you have a clear view of the sky?

Did you enter the number in international format?

All calls made from the Iridium® System require a special calling sequence; please refer to your Service Provider for these details.

Check the signal strength meter. If the signal is weak, move the vehicle to a more open area.

Check the Network Selection settings.

Check your Operator coverage map.

Is Restricted displayed? Check the Call Barring setting.

Has a new SIM card been inserted?

You can't receive calls?

Check to see your phone is powered on.

Is the phone registered onto the network?

Check the Antenna. Is it mounted properly.

Do you have a clear view of the sky?

Check the signal strength. If the signal is weak, move the unit to a more open area.

Check all forwarding and call barring settings.

Check the ringer setting.

You cannot make international calls.

Have you included the relevant codes? Press and hold the (+) key to display the international dialing prefix (+), and then enter the appropriate country code, followed by the phone number. Check the Call-Processing settings in the Beam Management System if applicable. All calls made from the Iridium® System require a special calling sequence, please refer to your Service Provider for these details. Did you enter the number in international format? Check the signal strength meter. If the signal is weak, if possible, move the antenna to a more open area. Is Restricted displayed? Check the Call Barring setting. Has a new SIM card been inserted? Is it active?



TERMINAL SETTINGS

My Terminal / IsatPhone Pro displays a language I do not understand.

Press the red key to return to the main screen

Press the left selection key to go to the menu screen

Press the down navigation key twice to highlight the Settings icon

Press the centre selection key to open Settings

Press the down navigation key twice to highlight the Language icon and press the centre selection key

Press the centre selection key and use the navigation keys to highlight the correct language and press the centre selection key again to change the terminal's language

STATUS LED'S

What does it mean when the LED status is flashing RED/BLUE?

The LED Status flashing RED/BLUE is an indicator that there has been an error detected in communication with the IsatPhone Pro handset. Remove the IsatPhone Pro handset, recycle power to the Docking Station and reinsert the IsatPhone Pro handset.

ACCESSORY WIRE

The unit does not turn off immediately after the accessory wire connection going low.

By default, the docking station will keep the satellite phone ON for a period of 20 minutes after the accessory wire connection goes low.

This is intended to allow users to turn OFF their vehicle/asset yet still receive calls for a short period.

This 20-minute timeout period can be adjusted via configuration software.